

modempak

INNOVATIVE DESIGN • FLEXIBLE APPLICATION • EASY INSTALLATION

C-SERIES COMMUNICATIONS RACK



CR001

C-SERIES COMMUNICATIONS RACK

As world leaders in the design and manufacture of communications cabinets, the Modempak range of C-Series cabinets are the perfect combination of ergonomic style, quality and functionality. Designed in consultation with data professionals, our range of C-Series cabinets are renowned for capacity, security and functionality. Available in a variety of sizes and configurations C-Series cabinets provide a flexible solution for your organisation regardless of the scope or complexity of your network infrastructure.

KEY FEATURES

- Two shelves, two way fan kit for 600d cabinets, 4 way fan kit for cabinets greater than 600d, adjustable levelling feet and one set of castors included as standard.
- Static load capacity of up to 600kg.
- Quick Release removable sides to allow for easy access to cables and equipment (lockable option available).
- Doors can be easily removed and hinged left or right.
- Toughened Safety Glass door & Steel door standard (perforated door option available).
- Complies with ANSI/EIA RS-310-D, IEC297-2, DIN41491; PART 1, DIN41494; PART 7, GB/T3047.2-92, IP20 rated.
- RU numbers on vertical rails.
- Modular design.
- Earthing point on vertical rail.
- 4 point horizontal stiffeners.
- Adjustable levelling feet included.
- Cable entry gland plates on top & bottom panels.
- Vertical cable management left & right, front & back with clip-on lids as standard on all 800w cabinets (90w x 50d c/w 7 x rings)
- Supplied fully built - no assembly required.
- Cabinets can be spliced together for bayed rows.
- Fitted with Cam-lock (other options maybe available upon request).
- Standard colour is Carbon Ripple - textured finish that is mark and scratch resistant.



Fan unit

Removable side panels
(Provision for lock - optional extra)



4-point horizontal stiffeners



RU numbering on vertical rails



Adjustable Levelling Feet

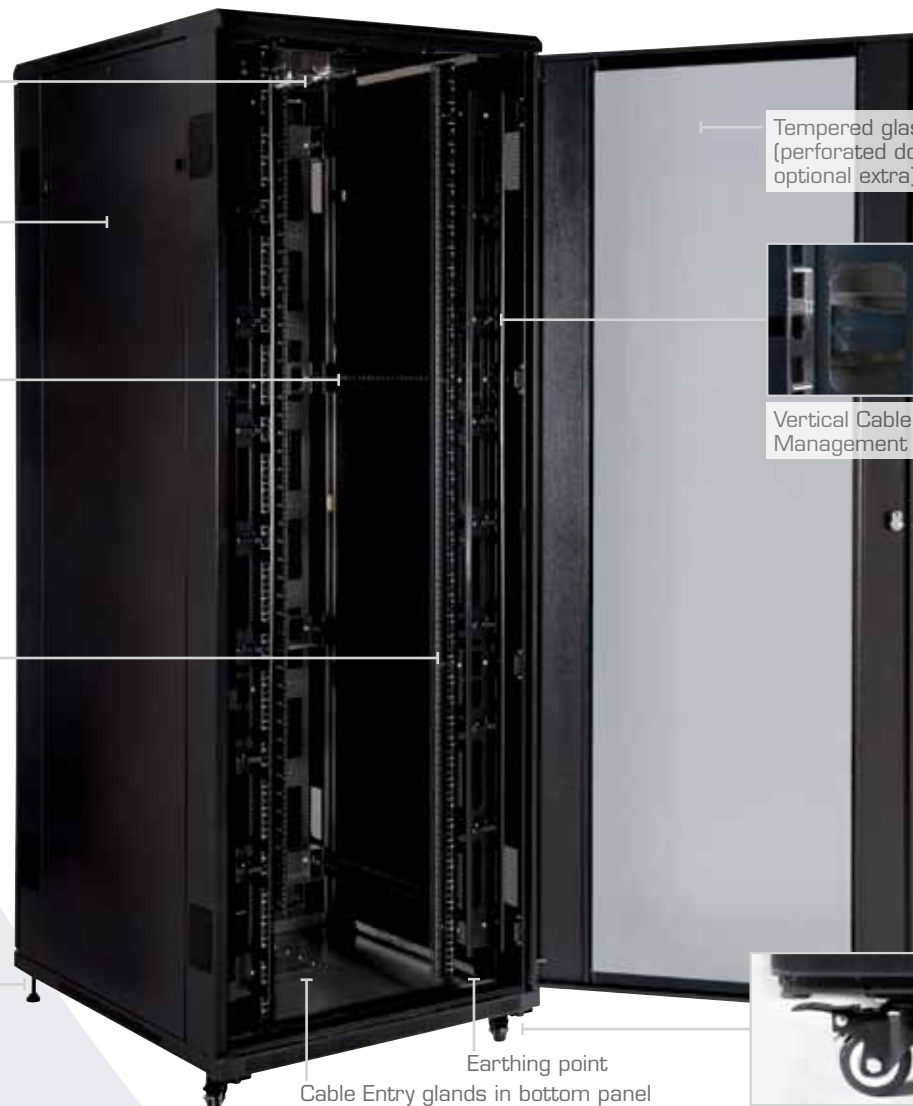

Tempered glass door
(perforated door - optional extra)



Vertical Cable Management Troughs

Cable Entry glands in bottom panel



Castors

4 FAN KIT



STANDARD SHELF



VERTICAL CABLE MANAGEMENT TROUGH



TOP PANEL

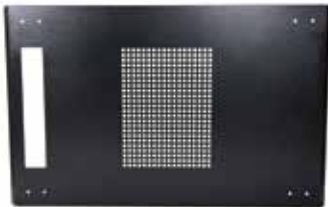

BOTTOM PANEL



TYPICAL APPLICATIONS

- Communications rooms.
- Office environments.
- Small/medium server installations.

TABLE OF SIZES

HEIGHT MM	WIDTH	DEPTH	PRODUCT
1200 (25RU)	600mm	600mm	31110008
1200 (25RU)	600mm	800mm	31110009
1800 (38RU)	600mm	600mm	31110018
1800 (38RU)	600mm	800mm	31110019
1800 (38RU)	600mm	960mm	31110020*
1800 (38RU)	600mm	1000mm	31110021*
2100 (45RU)	600mm	600mm	31110028

HEIGHT MM	WIDTH	DEPTH	PRODUCT
2100 (45RU)	600mm	800mm	31110029
2100 (45RU)	600mm	960mm	31110030*
2100 (45RU)	600mm	1000mm	31110031*
2100 (45RU)	800mm	800mm	31110034
2100 (45RU)	800mm	960mm	31110035*
2100 (45RU)	800mm	1000mm	31110036*

* All 960d cabinets will be phased out over the course of 2011 and be replaced with the new 1000d cabinets.

CPO1

C-SERIES CABINET ACCESSORIES

A full list of Cabinet Accessories can be found in the Modempak Cabinet & Patch Accessories brochure - CPO1. The brochure includes but is not limited to:

- Power Rails
- Intelligent Power Rails
- Cable Management
- Plinth Base
- Telescopic Chimney
- Shelving

modempak

TECHNICAL DETAILS

C-SERIES CABINET

- Static Load Capacity: 600kg
- Available cabling space per side 15mm (600 wide)
- Available cabling space per side 105mm (800 wide)
- All Steel construction

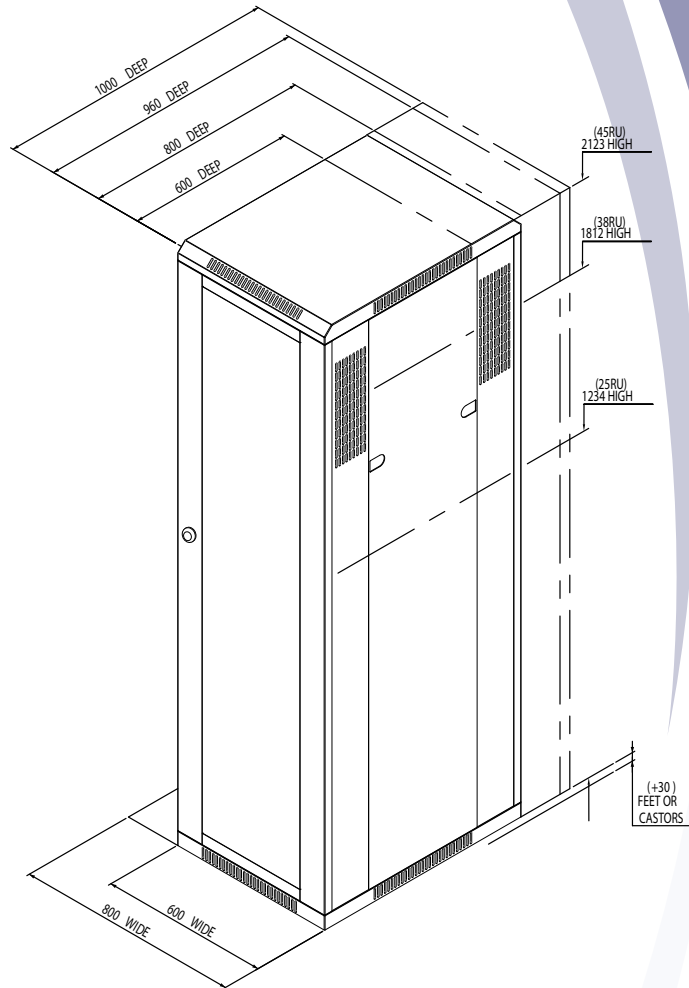
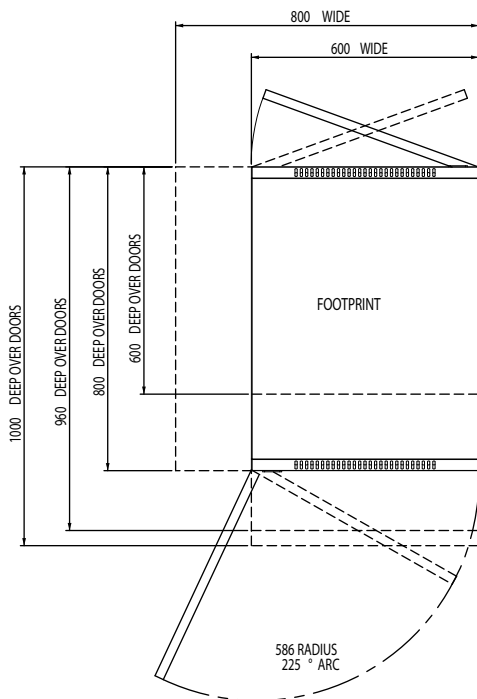

MODEMPAK LTD

16 Hugo Johnston Drive
PO Box 12525, Penrose
Auckland, New Zealand

Phone: +64 9 526 1880
Fax: +64 9 580 0606
Freephone: 0800 MODEMPAK
(0800 663 367)
Freefax: 0800 329 636

www.modempak.co.nz

Member of the ESCO
group of companies



ESCO

Melbourne

Unit 4, 15 Lilee Crescent
Tullamarine, Victoria 3043
Australia

Phone: +61 3 9310 3980
Fax: +61 3 9338 5547

www.modempak.com.au

ESCO

Sydney

Unit 37, Slough Business Park
Holker Street, Silverwater
NSW 2128, Australia

Phone: +61 2 8799 3700
Fax: +61 2 8799 3710

www.escoindustries.com.au

Distributor:

