



Seismic Server Rack

Heavy Duty • High Security • Seismic Rating



www.modempak.com

S - SERIES

Accessories



High Performance Cooler



Power Panel



Sliding Shelf



Keyboard sliding shelf with built in keyboard & mouse

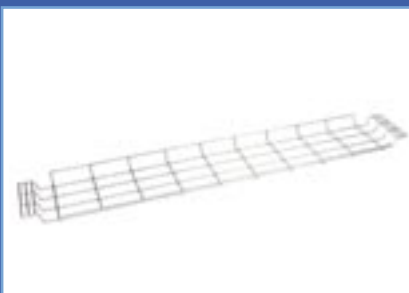

Cable Trays

Features

- Load capacity of up to 1000kg
- 3 point locking
- Designed and tested to exceed Bellcore™ standard zone 4 Seismic rating
- Heavy duty convex doors front and rear that are perforated for superior heat transfer
- Interchangeable doors that can hinge either left or right
- Reinforced heavy duty side panels for increased strength and security
- Pre-drilled holes in steel frame to secure cabinet to floor
- Sliding vertical rails to allow adjustment of equipment depth while cabinet fully loaded

Accessories

In addition to those shown on the left

- LCD keyboard drawer – 8 or 16 port KVM
- Intelligent power rails
- Electronically controlled doors
- Cantilever shelf
- Multipurpose base (plinth)

Typical Applications

- Data centres
- Blade server installations
- Broadcasting environments
- High security situations
- High seismic activity areas

www.modempak.com

Seismic Server Rack

Removable, reinforced heavy duty side panels

Split front and rear door option

Perforated door for superior ventilation



Convex doors front and rear

One-piece doors can hang to left or right

Adjustable vertical rail

Reinforced frame tested to Bellcore™ zone 4

Table of Sizes

Height	Depth	Width	Product
2100 (45RU)	1000 mm	600mm	11010001
2100 (45RU)	1200 mm	600mm	11010002
2100 (45RU)	1000 mm	800mm	11010010

Technical Information

- Unloaded Weight
125 kg (600x1000)
- Load Capacity
1000 kg
- Available cabling space per side
55mm (600 wide)
- Available cabling space per side
155mm (800 wide)

For further technical information
visit our website

www.modempak.com

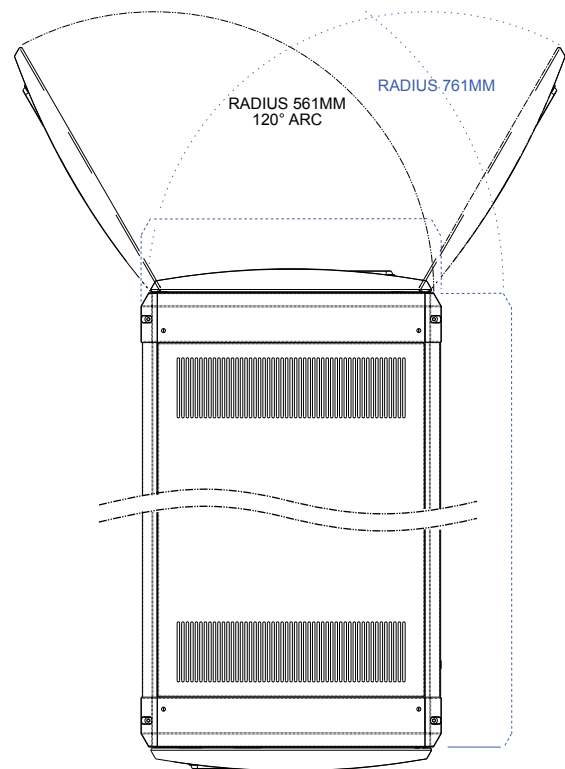
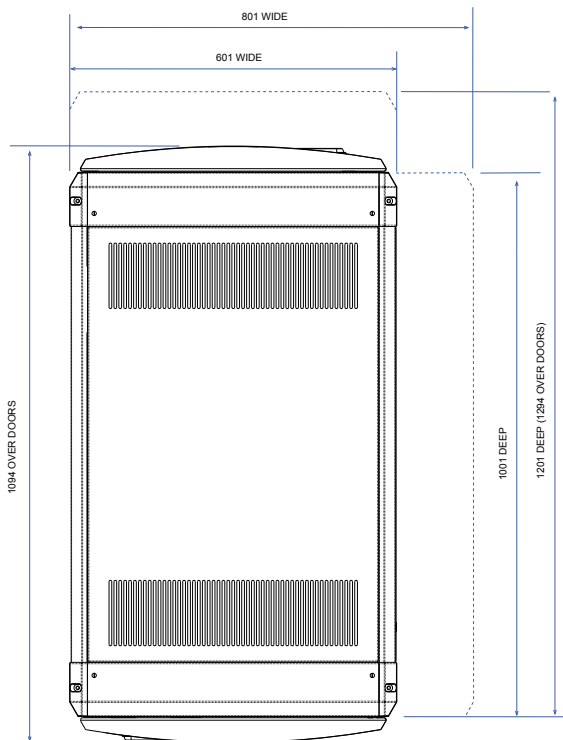
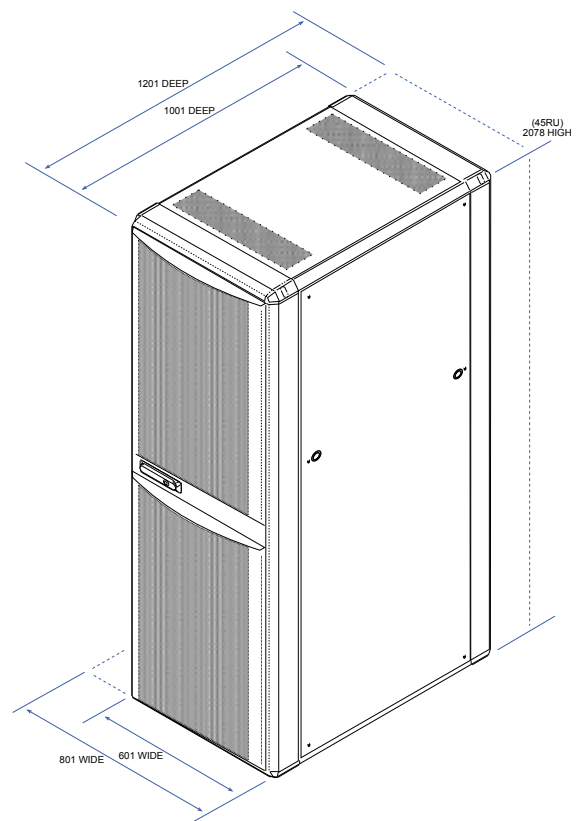

Modempak Limited

417a Church Street
PO Box 12525, Penrose
Auckland, New Zealand

Freephone 0800 663 367
Freefax 0800 329 636
Website www.modempak.com

Modempak PTY Limited

10 Kembla Street
Cheltenham, Vic 3192
Australia

Phone +61 3 9584 1955
Fax +61 3 9584 1933
Website www.modempak.com.au